

CONTROL UNIT – AV6 MT

GUIDE FOR INSTALLATIONS

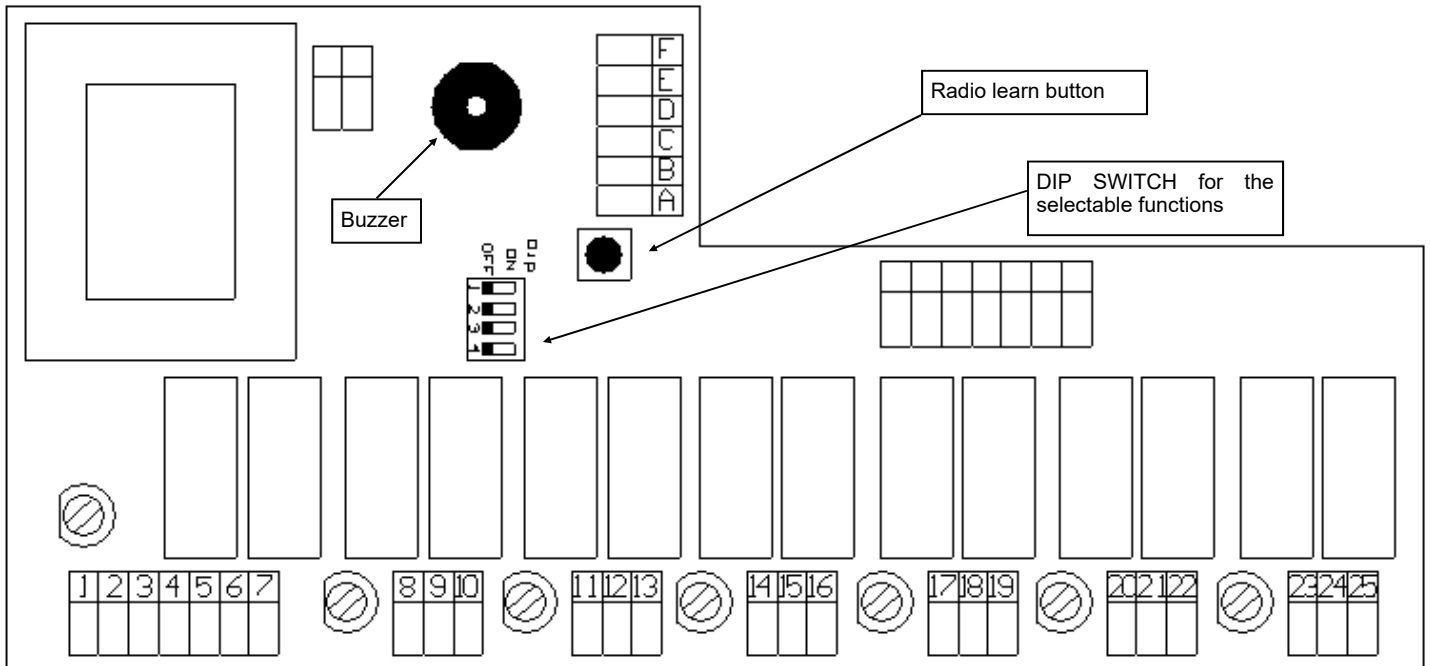

1. Configuration



2. Electrical connections

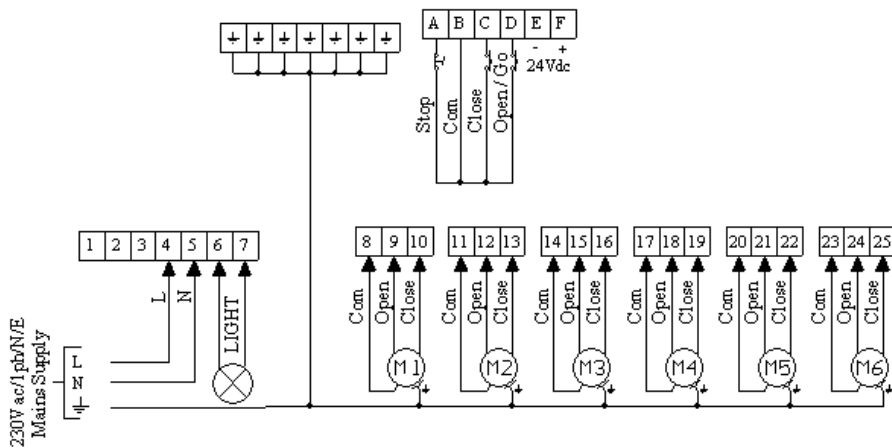

All normally closed (N.C.) contacts need to be jumped in case these won't be used.

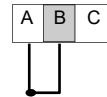

Individual Control

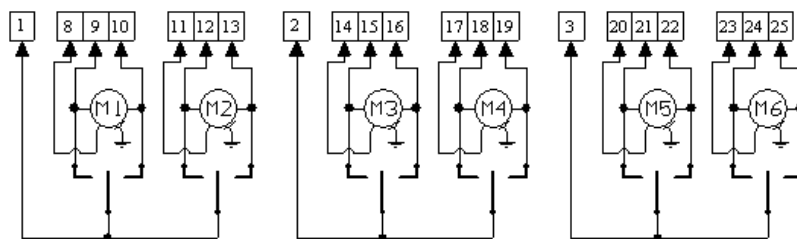

Working of the individual control

The individual control allows to move the automation by excluding the control unit. The individual control will be excluded when the control unit operates a movement.

WARNING: ACTIVATE ONLY ONE MOTOR AT A TIME

ATTENTION: Before starting up, please read carefully the following paragraphs which describe the programming and main settings of the automation. While programming, follow strictly the order and the indicated instructions. Do not enter in the action range of the automatism while it's in movement or while programming. Before carrying out any modifies please wait that there is a completely standstill of the automatism. Do not allowed external and or not qualified personal to carry out any operations and/or presences in the action range of the system.

3. Selectable functions through the dip switch

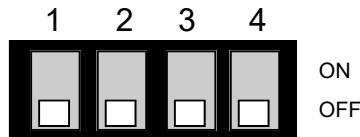

DIP1:

- **If positioned on OFF:** the active function in the **OPENING BUTTON** is the one called **“DEAD MAN OPERATION”**. The opening of the automation continues until the button itself is pressed. When the button is released the automation stops.
- **If positioned on ON:** A momentarily pressing of the **OPENING BUTTON** determines the **complete opening** of the automation. **The opening can be stopped** with the **stop** button or by a **close** operation in any moment.

DIP2:

- **If positioned on OFF:** The active function in the **CLOSING BUTTON** is the one called **“DEAD MAN OPERATION”**. The closing of the automation goes on until the button itself is pressed. When the button is released the automation stops.
- **If positioned on ON:** A momentarily pressing of the **CLOSING BUTTON** determines the **complete closing** of the automation. The closing can be stopped with the **stop** button or by an **open** operation in any moment.

DIP3: WORKING TIME

- **If the Dip is positioned on OFF:** the automation has a maximum working time of **3 minutes**
- **If the DIP is positioned on ON:** the automation has an **infinite** working time

DIP4: INPUT WORKING (as you can see in the scheme on the previous page).

- **If the DIP4 is positioned on OFF:** you have the possibility to connect three buttons **“STOP, OPEN, CLOSE”** on the control board. In this case the DIP 1 and the DIP2, as mentioned above, will determine the working modality of the inputs.
- **If the DIP4 is positioned on ON:** you have the possibility to connect the operations of two buttons **“STOP, STEP by STEP”** on the control board. In this case the working will be determined by the sequence **OPEN-STOP-CLOSE....**

The DIP1 and DIP2 needs to be set on ON for enabling this function.

N.B: The functions of the transmitter are the same as those set for the buttons by wire.

4. Learning of the transmitters (only with the installed radio)

The learning of each single transmitter needs always to be carried out **while the automation is standing**, and can be done in two different ways:

4.1. By using the learn button

Press once the learn button

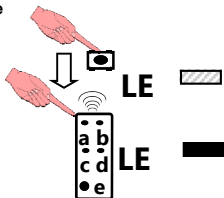

LEARNING:

- 1) Press the present LEARN button on the control unit. The control unit emits a sequence of beeps (by means of a present buzzer on the card)
- 2) Press the button “a” of the transmitter. The control unit memorizes automatically as well the button “b” (“a” as an “open” button and “b” as a “close” button). The control unit turns in the normal working modality, once the couple of buttons have been memorized

4.2. Learning of the following transmitters with the hidden button of an already learned transmitter.

Press once the hidden button “e”

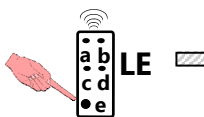

LEARNING:

- 1) Press the hidden button “e” present on the previously learned transmitter. The control unit emits a sequence of beeps (by means of a buzzer present on the card). This operation is the same as pressing the LEARNING button but without entering physically in the control unit.
- 2) Repeat point 2) of the paragraph 4.1



ATTENTION: Do not use this procedure while other control units are working, as the opening of the memory would take place for all devices in whom the transmitter is memorized. Cut the tension of the control units which are not involved.

The control unit waits for the transmitter which needs to be memorized for 20 seconds, at the end returns in the normal working modality.

5. Total reset of the memory

For carrying out a total reset of the memory it's necessary to cut the power supply, by keeping pressed the learn button the system will be supplied again. The buzzer emits beeps for three seconds. When the beeps have finished, release the button. The reset is finished.

ATTENTION: ALL MEMORIZED TRANSMITTERS WILL BE CANCELLED BY USING THIS OPERATION!!

GUARANTEE - In compliance with legislation, the manufacturer's guarantee is valid from the date stamped on the product and is restricted to the repair or free replacement of the parts accepted by the manufacturer as being defective due to poor quality materials or manufacturing defects. The guarantee does not cover damage or defects caused by external agents, faulty maintenance, overloading, natural wear and tear, choice of incorrect product, assembly errors, or any other cause not imputable to the manufacturer. Products that have been misused will not be guaranteed or repaired. Printed specifications are only indicative. The manufacturer does not accept any responsibility for range reductions or malfunctions caused by environmental interference. The manufacturer's responsibility for damage caused to persons resulting from accidents of any nature caused by our defective products, are only those responsibilities that come under Italian law.